



Pinnacle™ 250

VIEW Pinnacle 250 from QVI® delivers unmatched accuracy and throughput, with the lowest cost of ownership for any automated measuring system of its kind.

State-of-the-art linear motor control technology provides the fastest, most reliable platform available for high volume operation in production environments ranging from cleanrooms to factory floors.

- High speed linear motor X-Y stages
- High precision single or dual magnification fixed lens optical system
- Advanced image processing for high speed, accuracy, and precision

	X	Y	Z
Travel (mm)	250	150	100

High Throughput, High Accuracy Metrology System



Standard Metrology Software

- VIEW Metrology Software (VMS)

Optional Metrology Software

- Elements® Metrology Software
- Measure-X® Metrology Software

Optional Software Modules

- Area Multi-Focus (AMF)
- Extended Depth of Field Image (EDFI)
- Continuous Image Capture (CIC)
- Advanced Image Processing
- COM and Custom UI
- MeasureFit® Plus
- SmartProfile® GD&T Evaluation Software
- VMS Offline Image Processing Workstation

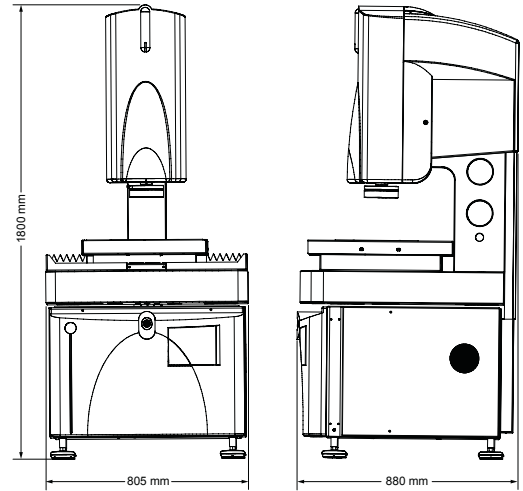

System Weight: 605 kg
Shipping Weight: 785 kg

	Standard		Optional		
XYZ travel	250 x 150 x 100 mm				
XYZ scale resolution	0.1 µm, zero expansion material ¹		0.05 µm, zero expansion material ¹		
Stage drive system	High speed linear motor drives X&Y, DC servo motor Z				
Max recommended load	25 kg				
Imaging optics	Single magnification, fixed lens optics with factory configurable back tube and field interchangeable front lens		Dual magnification, fixed lens optics with field interchangeable front lens		
Back tube (factory installed)	VIEW 1X back tube		VIEW 2X back tube (Available for single magnification optics only. FOV changes when 2X back tube applied.)		
Standard front lens	VIEW 2.5X	FOV 2.78 x 2.07 mm	VIEW 2.5X (DMO)	FOV Low: 2.78 x 2.07 mm FOV High: 0.64 x 0.48 mm	
Optional front lenses (field interchangeable)			Lens Option	Single Mag FOV	Dual Mag FOV
			VIEW 0.8X	8.34 x 6.23 mm	Low: 8.34 x 6.23 mm High: 1.91 x 1.43 mm
			VIEW 1X	6.46 x 4.82 mm	Low: 6.46 x 4.82 mm High: 1.59 x 1.19 mm
			VIEW 5X	1.35 x 1.01 mm	Low: 1.35 x 1.01 mm High: 0.31 x 0.23 mm
			VIEW 10X	0.69 x 0.52 mm	Low: 0.69 x 0.52 mm High: 0.16 x 0.12 mm
			VIEW 25X	0.28 x 0.21 mm	Low: 0.28 x 0.21 mm High: 0.06 x 0.05 mm
Metrology camera	2.0 megapixel (1628 x 1236), digital, monochrome metrology camera		Color and other camera configurations are optionally available		
Illumination	Programmable LED illumination system for coaxial through-the-lens surface light, below-the-stage backlight, and multi-color ring light with motorized incidence angle control		Grid autofocus system		
Sensor options			Through-the-lens (TTL) laser Rainbow Probe™ off-axis white light range sensor		
Measurement modes	High Speed Move And Measure (MAM)		Continuous Image Capture (CIC)		
System controller	Intel® processor based Microsoft® Windows® operating system and on-board networking and communication ports				
Controller accessory package	QVI multifunction handheld controller with 3 axis joystick and illumination controls		Single LCD flat panel display, computer keyboard and mouse Dual LCD flat panel displays, computer keyboard and mouse Space saving operator workstation desk with dual monitor mounts		
Power requirements	100-120 VAC or 200-240 VAC, 50/60 Hz, 1 phase, 1500 W				
Safe operating environment	15-30 °C				
Rated environment	Temperature 18-22 °C, stable to ±1 °C, max rate of change 1 °C / hour, max vertical gradient of 1 °C / meter; 30-80% humidity; vibration <0.001 g below 15 Hz				
XY area accuracy	E _z : (1.0+5L/1000) µm				
Z linear accuracy	E _r : (1.5+5L/1000) µm		E _r : (1.0+5L/1000) µm (requires Rainbow Probe)		

Accuracy is evaluated with a QVI verification procedure where "L" is measured length in millimeters. Specifications apply within the rated environment. Accuracy specifications are applicable when configured with a 2.5X or higher front objective lens. XY Accuracy applies with an evenly distributed load up to 5 kg in the standard measuring plane. The standard measuring plane is defined as a plane that is within 25 mm of the worktable surface. Depending on load distribution, accuracy at maximum payload may be less than standard. Accuracy specifications do not apply to Continuous Image Capture (CIC) mode.



VIEW, a division of Quality Vision International

1711 W 17th Street • Tempe, Arizona 85281-6229 • USA
Phone: (480) 295-3150 • (800) SOS-VIEW • Fax: (480) 889-9059
sales@viewmm.com • viewmm-service@qvii.com
www.viewmm.com